

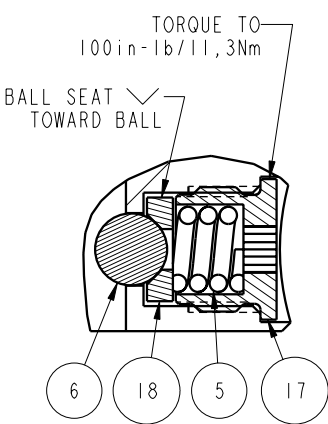

APPLY LUBRICANT TO ALL SEALS
PRIOR TO INSTALLATION.
DO NOT USE SILICONE TYPE LUBRICANTS.
FOR PROPER ARM MOUNTING SEE IS1505.



DETAIL A
SCALE 1.500

N/A	N/A	IS1505	INSTRUCTION SHEET, ARM INSTALLATION		
N/A	N/A	6V711042	SEAL KIT, FKM		
N/A	N/A	60711042	SEAL KIT, STANDARD		
20	1	81591822	CAM, SC, LP, 5000/22KN, RH, TC		
19	1	81541807	BASE, SC, BF, LP, 22kN		
18	3	81532108	SEAT, BALL, SC, LP, TC		
17	3	81532107	RETAINER, SC, LP, TC		
16	1	81511811	PLUNGER, SC, LP, 5000/22KN, DA, TC		
15	2	43068006	PLUG, 1/4 BSPP MALE		
14	1	39054008	BU RING, (-218), HYTREL	X	X
13	1	39054007	BU RING, (-030), 90 NBR	X	39054021
12	1	39053005	WIPER, SNAP-IN, (1-1/4), 90 FKM	X	X
11	1	39051042	O-RING, (-030), 1.814x.070, 90 HNBR	X	39V01021
10	2	39051041	O-RING, (-006), 1.114x.070, 90 HNBR	X	39V51041
9	2	39050042	O-RING, (-011), .301x.070, 90 AUD	X	39051025
8	1	39011060	SEAL, BEV, INSR, 1.25x.125x1.5, 85 HNBR	X	39052015
7	1	39011056	SEAL, CROWN, 1-9/16x1-3/4x5/32, 90AU	X	39V11056
6	3	23650004	BALL, TUNGSTEN-CARBIDE, 250		
5	3	23350066	SPRING, COMP., .296X.06X.31X.21, 903		
4	2	21500200	WASHER, .124x.207x.024, COPPER		
3	3	21500031	SHCS, M5 x 0.8 x 14, ALY		
2	10	21500023	SHCS, M5 X .8-66 X 30MM		
1	2	21500019	SCREW, CAP, BTNH, M3 X 6, ALY		
No.	QTY	PART No.	DESCRIPTION	Std. Seal Kit	FKM Seal Kit

PARTS LIST	 VEKTEK VEKTEK, INC. 1334 E. SIXTH AVE. P.O. BOX 625 EMPORIA, KS. 66801 U.S.A.
	ASSEMBLIES AFFECTED 41422221
SIZE A	MPL7164
REV B	FORM FEG035_PL_ASIZE, REV. A

B	2583	RELEASE	JDW	10/29/13
REV	IN ACCORDANCE WITH ECN	EFFECTIVE DATE	REVISED BY	DATE
DRW BY:	JDW	DRAWING STATUS: Released PRODUCTION APPROVED FOR RELEASED STATUS ONLY		
DATE:	6-17-11			

1 **2**

READ ALL INSTRUCTIONS BEFORE INSTALLING ARMS FAILURE TO FOLLOW INSTALLATION INSTRUCTIONS WILL VOID PRODUCT WARRANTY !

-Installing or Positioning of Low Profile Swing Clamp Arms-

**NOTE: If the arm is already installed on the plunger,
loosen the cap screw.**

**CAUTION: Never attempt to rotate the arm before loosening
the cap screw. This can damage the plunger rotating mechanism.**

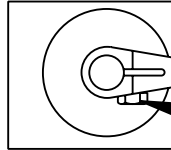

1. Rotate the arm to the desired radial position.
2. Tighten to the torque specification listed below.

MODEL	TORQUE ft-lb	TORQUE N-m
15-XX18-XX (5000lb) 14-XX18-XX (5000lb)	115	156
41-XX22-XX (22Kn)	115	156
6951KN-22-XX (22Kn) 6951KN-22-XXX (22Kn) 6951KZN-22-XX (22Kn) 6951FN-22-XX (22Kn) 6951FZN-22-XX (22Kn)	115	156
6951KP-22-XX (22Kn) 6951KP-22-XXX (22Kn) 6951KZP-22-XX (22Kn) 6951FP-22-XX (22Kn) 6951FZP-22-XX (22Kn)	115	156
15-XX21-XX (7500lb) 14-XX21-XX (7500lb)	225	305
41-XX33-XX (33Kn)	225	305
6951KN-33-XX (33Kn) 6951KN-33-XXX (33Kn) 6951KZN-33-XX (33Kn) 6951FN-33-XX (33Kn) 6951FZN-33-XX (33Kn)	225	305
6951KP-33-XX (33Kn) 6951KP-33-XXX (33Kn) 6951KZP-33-XX (33Kn) 6951FP-33-XX (33Kn) 6951FZP-33-XX (33Kn)	225	305

Instruction Sheet



VEKTEK, INC.
1334 E. SIXTH AVE. P.O. BOX 625
EMPORIA, KS. 66801 U.S.A.

B	2288	RELEASE	JDW	6-9-11
REV	IN ACCORDANCE WITH ECN	EFFECTIVE DATE	REVISED BY	DATE
DRW BY:	MES	DRAWING STATUS: Released		
DATE:	08/01/05	PRODUCTION APPROVED FOR RELEASED STATUS ONLY		

ASSEMBLIES AFFECTED

Arm Installation Instruction Sheet

Low Profile Swing Clamps

SIZE	A	REV	B
------	---	-----	---

FORM FEG041-1S-ASIZE, REV. A